

Chapter 2: Main Paragraph of Article 3(1)

Article 3

Any trademark to be used in connection with goods or services pertaining to the business of an applicant may be registered, unless the trademark:

Regulation for Enforcement of the Trademark Act

Article 4 Among trademarks whose characters, figures, symbols, three-dimensional shapes or colors in connection therewith change consisting of the characters, figures, symbols, three-dimensional shapes or colors or any combination thereof before and after the change (hereinafter referred to as “changing trademark”), the description of trademarks that change as time proceeds (hereinafter referred to as “motion mark”) in an application pursuant to the provision of Article 5(1)(ii) of the Trademark Act shall be made by one drawing or photograph or two or more different drawings or photographs indicating the state of change as time proceeds in an identifiable way.

Article 4-2 Among changing trademarks, the description of a mark that changes by holography or other means (excluding those listed in the preceding Article, hereinafter referred to as “holograph mark”) in an application pursuant to the provision of Article 5(1)(ii) of the Trademark Act shall be made by one drawing or photograph or two or more different drawings or photographs indicating the state before and after changes in an identifiable way.

Article 4-3 The description of a three-dimensional trademark (hereinafter referred to as “three-dimensional trademark”) consisting of a three-dimensional shape (including a combination with characters, figures, symbols or colors or any combination thereof; hereinafter the same shall apply in this Article) in an application pursuant to the provision of Article 5(1)(ii) of the Trademark Acts shall be made by any of the following methods:

- (i) drawings or photographs indicating the three-dimensional shape for which trademark registration is sought from one angle or two or more different angles; or
- (ii) drawings or photographs indicating three-dimensional shapes from one angle or two or more different angles in a way in which the three-dimensional shape for which trademark registration is sought is identified by drawing that three-dimensional shape with solid lines and other parts with broken lines.

Article 4-4 The description of a trademark consisting solely of colors in an application pursuant to the provision of Article 5(1)(ii) of the Trademark Act shall be made by any of the following methods:

- (i) drawings or photographs indicating the colors for which trademark registration is sought; or
- (ii) drawings or photographs indicating the colors and a position to which they are attached by drawing the colors for which trademark registration is sought with only the colors and other parts with broken lines.

Article 4-5 The description of a trademark consisting of sound (hereinafter referred to as “sound mark”) in an application pursuant to the provision of Article 5(1)(ii) of the Trademark Act shall be made by entering necessary matters for identifying the sound for which trademark registration is sought using characters or full score or a combination thereof; provided, however, that it may be described using one line stave in addition to the full score, if required.

Article 4-6 The description of a trademark for which a position to which a mark in connection therewith (limited to characters, figures, symbols or three-dimensional shapes or any combination thereof or any combination thereof with colors) is attached is specified (hereinafter referred to as “position mark”) in an application pursuant to the provision of Article 5(1)(ii) of the Trademark shall be made by one drawing or photograph or two or more different drawings or photographs indicating the way in which the mark and the position to which it is attached is specified by drawing the mark with solid lines and other parts with broken lines.

1. “Business of an Applicant”

The “business of an applicant” shall include the business of the applicant himself/herself as well as the business of any person who is substantially recognized as being under control thereof.

(Examples)

- (i) Business of a stock company of which the majority of voting rights of all shareholders are owned by the applicant;
- (ii) Business of a company which has a capital alliance with the applicant and whose corporate activities are substantially under control of the applicant, although the requirement specified in (i) above is not satisfied.
- (iii) Business of an affiliated store (franchisee) if the applicant is a franchiser in a franchise agreement.

2. “Trademark is used”

(1) The expression of “a trademark is used” includes not only cases where the applicant or any person who is substantially recognized as being under control thereof (hereinafter referred to as “the applicant, etc.”) actually uses the trademark as applied in connection with the designated goods or designated services but also cases where the applicant, etc. has the intention to use the trademark as applied (hereinafter referred to as the “intention of use”) in the future.

(2) The designated services falling under, for example, the following example will receive a notification of reason for refusal stating that the trademark does not fall within the category of trademarks registrable in accordance with the main paragraph of Article 3(1), because it is likely that it is impossible to use the trademark, and whether the applicant may carry out the designated services or not shall be confirmed.

(Example)

If it is obliged to have any national qualification prescribed in laws and regulations to execute a business in connection with the designated services, it is not able to confirm whether the applicant is a juridical person that may execute the business connected with the designated services from the applicant’s name or other matters described in an application or the applicant has the national qualification as an individual

(3) A designated good or designated service falling under the following (a) or (b) will receive a notification of reason for refusal stating that the trademark does not fall within the category of trademarks registrable in accordance with the main paragraph of Article 3(1), because there is a justifiable doubt as to whether the applicant is using, or planning to use, a trademark connected with the designated good or designated service. The use or intention of use of the trademark will be ascertained in accordance with Item 3 below.

However, this shall not apply where the applicant, at the time of filing an application, was using or planning to use the trademark, by which use or intention of use of the trademark can be ascertained.

(a) Regarding services provided for in Article 2(2) of the Trademark Act (hereinafter referred to as “retail services”)

(i) Where a person (natural person) has designated services falling under the category of “provision of benefits to customers in retail services or wholesale services for a variety of goods in each of the

fields of clothing, foods and beverages, and livingware, and taking all goods together” (hereinafter referred to as “general retail services”).

(ii) Where a juridical person has designated services falling under the category of general retail services, and if the investigation as to whether or not the trademark will be “used in connection with goods or services pertaining to his business” found out that the applicant is not conducting general retail services.

(iii) Where more than one of the retail services have been designated that are not similar to each other.

(b) Regarding overall goods and services other than those mentioned in (a) where the designation of goods or services ranges widely in one classification.

3. Ascertaining of whether a trademark will be used

(1) It is required for the applicant to show the “trademark will be used” for each of the similar groups (Similar groups are referred to in the Examination Guidelines for Similar Goods and Services and group goods or services presumed to be similar to each other) in each of the classifications of the designated goods or designated services.

(2) The use or intention of use of the trademark will be ascertained through the fact that the applicant is conducting, or planning to start, business connected with the designated goods or designated services.

(3) Ascertaining of whether the applicant is conducting business The fact that the applicant is conducting business connected with retail services will be confirmed in the following manner.

(a) For retail services belonging to general retail services, it will be proved in a comprehensive manner by referring to the following facts:

(i) that the applicant is a retailer or a wholesaler.

(ii) that the above retailer or wholesaler is providing retail services at one establishment for a variety of goods in each of the fields of clothing, foods and beverages, and livingware, and taking all goods together.

(iii) that the sales of each field of clothing, foods and beverages, and livingware is accounting for around from 10% to 70% of the total sales.

(b) The following, for example, will be accepted as means of proof that the applicant is carrying out business connected with the designated goods or designated services.

- (i) Printed matters (catalogs, leaflets, etc. containing the goods handled by the applicant, etc.)
- (ii) Photographs of the interior of the store operated by the applicant, etc. and of the goods handled by him
- (iii) Business documents showing the goods handled by the applicant, etc. (order forms, delivery statements, invoices, receipts, etc.)
- (vi) Articles on newspapers, magazines, the internet, etc. presenting the content of business of and the goods handled by the applicant, etc.
- (v) Documents stating the sales amount of goods in relation to retail services (in cases of general retail services)

(4) The fact that the applicant is planning to start business connected with the designated goods or designated services.

(a) Where the applicant shows his intention of starting to use the trademark within 3 to 4 years from the date of filing the application (within three years following the registration), he is judged to be planning to start business connected with the designated goods or designated services

(b) In order to prove that the applicant is planning to start business connected with the designated goods or designated services, the applicant thus will be requested to submit documents specifying his intention of use of the trademark and documents stating his preparation status.

Where his intension of use of the trademark is uncertain, or there is a doubt as to the relevant preparation status, the applicant will be requested, as needed, to submit further documents supporting the business operation and plan.

4. International application for trademark registration

(1) When the international registered trademark in the application for international registration does not correspond to the trademark the provisions of Article 2(1) of the Trademark Act for the international application for trademark registration, the trademark is judged not to fall within the category of trademarks registrable under the main paragraph of Article 3(1).

(2) A trademark described as corresponding to “a collective trademark” in the application of an international trademark registration is judged not to fall within the category of trademarks registrable in accordance with the main paragraph of Article 3(1) when the certificate prescribed in Article 7(3) (certifying the applicant as a juridical person that falls under Article 7(1)) is not submitted.

Furthermore, the application of collective trademark registration (domestic application) will be subject to amendment orders (formality).

5. Collective trademark

An application for registration of a collective trademark not to be used by an organization and its members or to be used for the designated goods and services only by an organization but not by its members is judged not to fall within the category of trademarks registrable under the main paragraph of Article 3(1) (as applied under Article 7(2)).

6. Three-dimensional trademark

A trademark stated as a three-dimensional trademark but not so recognized from the trademark stated in the column in which the trademark for which registration is sought is required to be stated (hereinafter referred to as the “column for stating the trademark”) in the application (hereinafter referred to as the “trademark stated in an application”) is judged not to fall within the category of trademarks registrable in accordance with the main paragraph of Article 3(1).

(1) Cases of indicating a three-dimensional shape (including that comprised of multiple three-dimensional shapes; the same shall apply hereinafter)

(a) Examples not recognized as three-dimensional trademarks

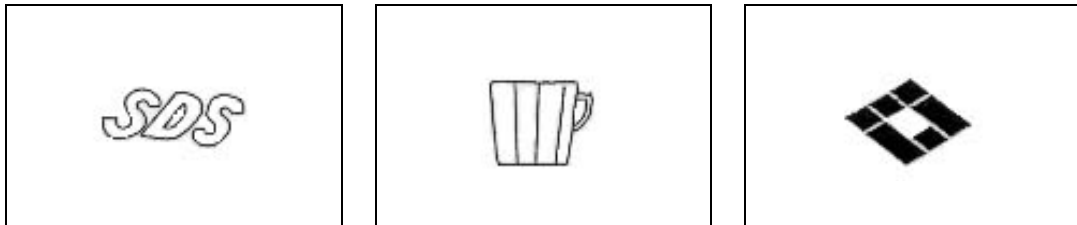

(Note) A shape as an outer appearance of a three-dimensional object, such as thickness, etc. as a three-dimensional shape, is not described, and the trademark is recognized as characters, a figure, or a symbol.

(b) Examples recognized as three-dimensional trademarks

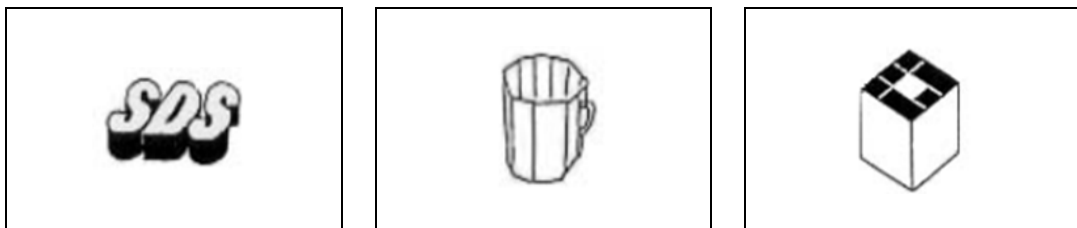

(Note) A shape as an outer appearance of a three-dimensional object, such as thickness, etc. as a three-dimensional shape, is described, and the trademark is recognized as a three-dimensional shape

or a combination of a three-dimensional shape and characters, figures, symbols, or colors.

(2) Cases not recognized as a combination of a three-dimensional shape and characters, figures, symbols, or colors



(Note) As the mark does not have a composition or mode where characters, figures, or symbols are affixed onto the surface of an object connected with a three-dimensional shape, but has a composition or mode where characters, figures, or symbols are separate from a three-dimensional shape, it is not considered to indicate a shape as an outer appearance of a three-dimensional object overall and it cannot be recognized as a three-dimensional trademark.

(3) Cases where multiple drawings are used to state the trademark stated in an application

(a) Examples not recognized as three-dimensional trademarks

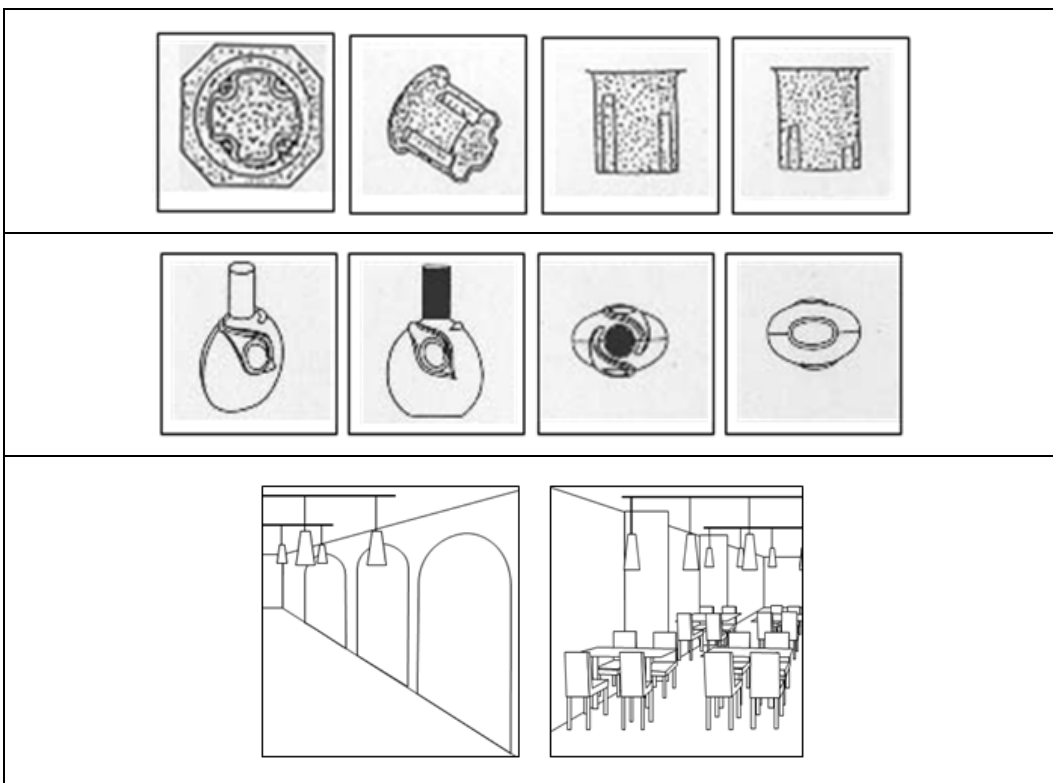

(Note) While multiple drawings are used to state the trademark, the three-dimensional shapes and colors indicated in the respective drawings do not match each other and are not identified as a single three-dimensional trademark.

(b) Examples recognized as three-dimensional trademarks

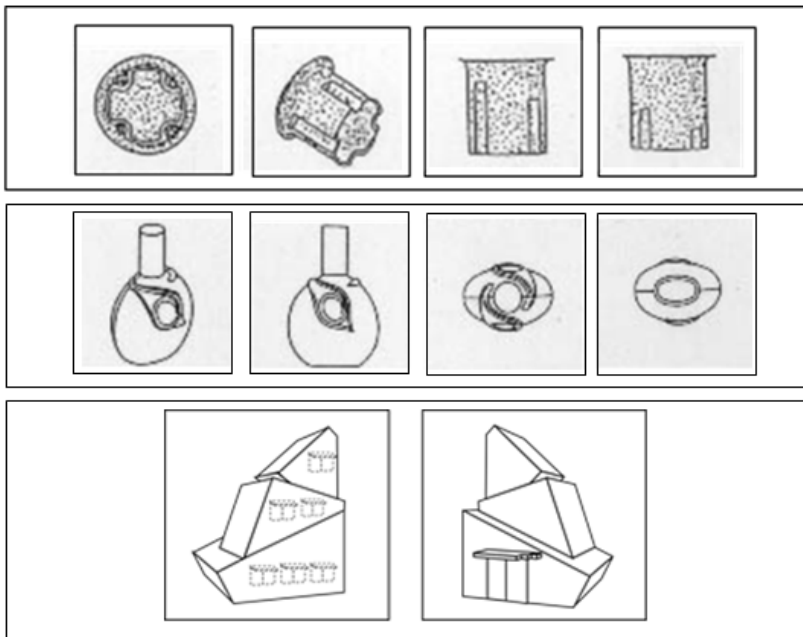

(Note) While multiple drawings are used to state the trademark, the three-dimensional shapes and colors indicated in the respective drawings match each other and are identified as a single three-dimensional trademark.

(4) Cases where a trademark is stated by drawing the mark in connection with the trademark with solid lines and other parts with broken lines, etc. (hereinafter referred to as “[having] parts drawn differently with solid lines/broken lines, etc.”)

(a) Examples not recognized as three-dimensional trademarks

(Examples)

(i) Case where there are parts drawn differently with solid lines/broken lines, etc., but there is no detailed description of the trademark

(ii) Case where there are parts drawn differently with solid lines/broken lines, etc., and a detailed description of the trademark, but there is no explanation on the parts that do not constitute the trademark (broken lines, etc.)

(b) Example recognized as a three-dimensional trademark

[Trademark for Which Registration Is Sought]

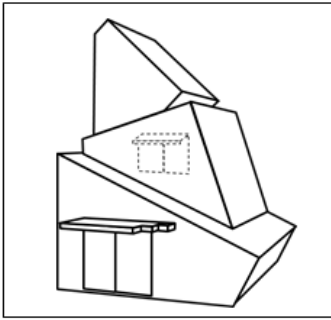

[Three-Dimensional Trademark]

[Detailed Description of Trademark]

A trademark for which registration is sought (hereinafter referred to as the “trademark”) is a three-dimensional trademark comprised of a three-dimensional shape indicating the outer appearance of a store including three polyhedrons.

It must be noted that the broken lines merely indicate an example of the shape of a store, and do not constitute a part of the trademark.

[Designated Goods or Designated Services and Classification of Goods and Services]

[Class 43]

[Designated Goods (Designated Services)] Providing foods and beverages

(Note) The trademark stated in the application has parts drawn differently with solid lines/broken lines, etc., and its composition and mode as a three-dimensional trademark are identified from the trademark stated in the application and the detailed description of the trademark.

(5) Cases where the edge of a three-dimensional trademark (if there are parts drawn differently with solid lines/broken lines, etc., the edge of the part that constitutes the trademark) is cut off by the frame of the column for stating the trademark

(a) Example not recognized as a three-dimensional trademark

[Trademark for Which Registration Is Sought]

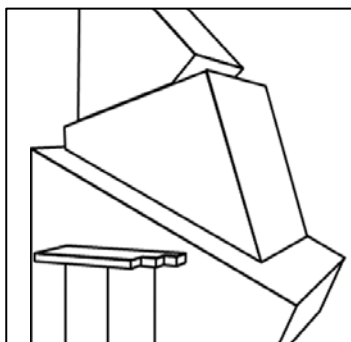

[Three-Dimensional Trademark]

[Detailed Description of Trademark]

The trademark for which registration is sought is a three-dimensional trademark indicating a part of the outer appearance of a store including three polyhedrons.

[Designated Goods or Designated Services and Classification of Goods and Services]

[Class 43]

[Designated Goods (Designated Services)] Providing foods and beverages

(Note) The trademark stated in the application does not indicate the entirety of the three-dimensional trademark, although it is possible to do so, so its composition and mode as a three-dimensional trademark are not specifically identified.

(b) Example recognized as a three-dimensional trademark

[Trademark for Which Registration Is Sought]

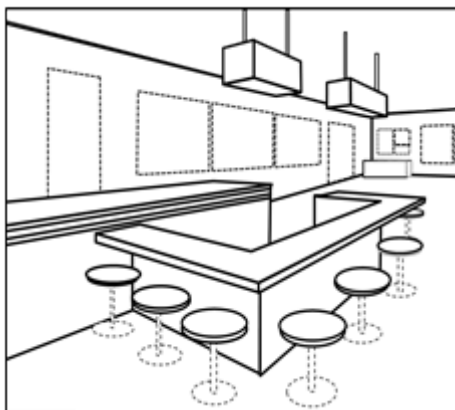

[Three-Dimensional Trademark]

[Detailed Description of Trademark]

The trademark relating to this application for trademark registration (hereinafter referred to as the “trademark”) is a three-dimensional trademark indicating the composition of the inside of a store, and it is comprised of a three-dimensional shape of the interior of a store including lighting apparatuses, a U-shaped counter, seats of stools, and a table for providing liquor and food, etc. installed adjoined to the counter.

It must be noted that the broken lines merely indicate an example of the shape of the interior of the store, and do not constitute a part of the trademark.

[Designated Goods or Designated Services and Classification of Goods and Services]

[Class 43]

[Designated Goods (Designated Services)] Providing foods and beverages

(Note) If a three-dimensional trademark indicates the composition of the inside of a three-

dimensional shape such as the interior, and it is unavoidable for the edge of the three-dimensional trademark to be cut off by the frame of the column for stating the trademark, the composition and mode as a three-dimensional trademark are judged to be identified within the scope stated in the column for stating the trademark only in the case that the statement of the detailed description of the trademark makes clear that it is a three-dimensional trademark indicating the composition of the inside of a three-dimensional shape.

(6) Cases of a three-dimensional trademark comprised of a composition including both the outer appearance and the interior

(a) Example not recognized as a three-dimensional trademark

[Trademark for Which Registration Is Sought]

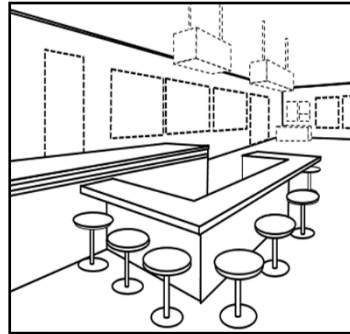
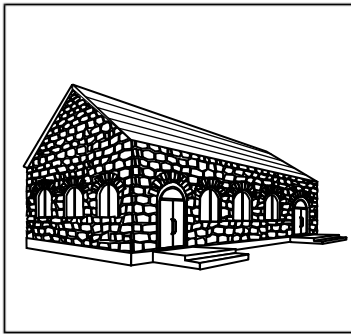

[Three-Dimensional Trademark]

[Detailed Description of Trademark] (Omitted)

(Note) For a three-dimensional trademark, if the outer appearance and the interior are stated in separate drawings, they are judged not to be identified as a single three-dimensional trademark.

(b) Example recognized as a three-dimensional trademark

[Trademark for Which Registration Is Sought]

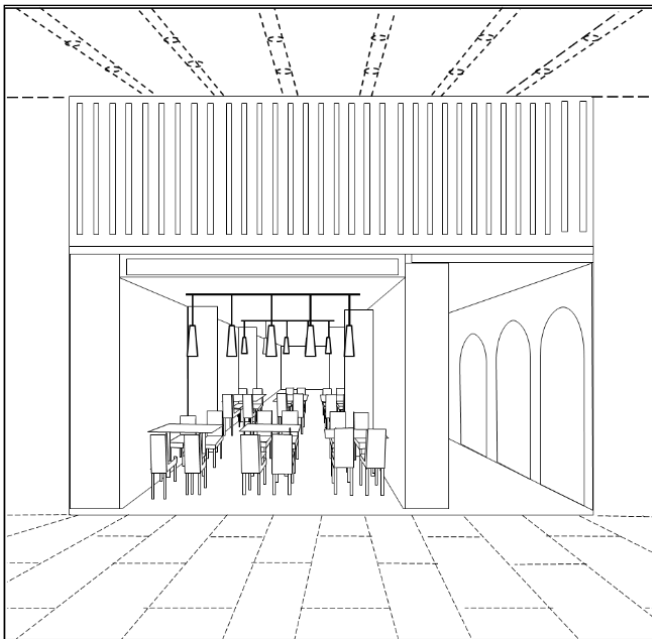

[Three-Dimensional Trademark]

[Detailed Description of Trademark]

A trademark for which registration is sought (hereinafter referred to as the “trademark”) is a three-dimensional trademark, and it is comprised of three-dimensional shapes indicating the outer appearance of a store including decorations of a vertical line pattern and the interior including tables, chairs, pendant lighting, and arched wall decorations.

It must be noted that the broken lines merely indicate an example of the shape of a building where a store is to be established, and do not constitute a part of the trademark.

[Designated Goods or Designated Services and Classification of Goods and Services]

[Class 43]

[Designated Goods (Designated Services)] Providing foods and beverages

(Note) The drawing indicating the outer appearance of the store includes the interior, so the trademark is judged to be identified as a single three-dimensional trademark.

(7) Case where “use” as a trademark cannot be naturally supposed

[Trademark for Which Registration Is Sought]



[Three-Dimensional Trademark]

[Designated Goods or Designated Services and Classification of Goods and Services]

[Class 5]

[Designated Goods (Designated Services)] Pharmaceutical preparations, sanitary masks

(Note) In this case, the trademark will receive a notification of reason for refusal stating that it does not fall within the category of trademarks registrable in accordance with the main paragraph of Article 3(1), since it is not naturally supposed that a designated good other than sanitary masks adopts the three-dimensional shape or is used as advertisement. In response to this notification, it is required to modify designated goods to only “sanitary masks.”

7. Motion Mark

A trademark stated as a motion mark but not so recognized from a trademark stated in its application as well as its detailed description shall be judged not to fall within the category of trademarks registrable in accordance with the main paragraph of Article 3(1).

(1) Example not recognizable as a motion mark

Changes of a mark in time cannot be recognized from a trademark stated in its application.

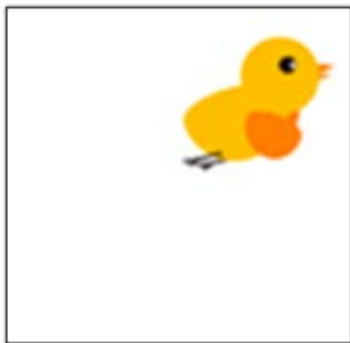

(Note) A trademark is stated in a single drawing and changes in time cannot be recognized because no pointing line is provided.

(2) Example recognizable as a motion mark

Changes of a mark in time are recognizable from a trademark stated in its application, and a description is provided in its detailed description of the trademark which makes it recognizable as a motion mark.

(Example 1) Example where one drawing is used to state a trademark (Example where the mark moves without changes)

[Trademark for Which Registration Is Sought]



[Motion Mark]

[Detailed Description of Trademark]

A trademark for which registration is sought (hereinafter referred to as the “trademark”) is a motion mark.

It is shown that a bird at the lower left gradually moves to the upper right along the trajectory of a dotted line. This motion mark lasts for 3 seconds in total.

Furthermore, the dotted line in the drawing is provisionally provided to indicate how the bird moves along the trajectory, and does not constitute a part of the trademark.

(Example 2) Example where multiple drawings are used to state a trademark

[Trademark for Which Registration Is Sought]



[Motion Mark]

[Detailed Description of Trademark]

A trademark for which registration is sought (hereinafter referred to as the “trademark”) is a motion mark.

It is shown that a bird moves gradually to the upper right from Drawing 1 to Drawing 5 with its wings up. This motion mark lasts for 3 seconds in total.

Furthermore, the numbers indicated at the lower right of individual pages are provisionally provided to show the sequence of the pictures, and do not constitute a part of the trademark.

8. Hologram Mark

A trademark stated as a hologram mark but not so recognized from a trademark stated in its application and its detailed description of the trademark shall be judged not to fall within the category of trademarks registerable in accordance with the main paragraph of Article 3(1).

(1) Example not recognizable as a hologram mark

Changes of its states cannot be recognized from a trademark stated in its application or from its visual effects based on holography and other means (such as those to show it as three-dimensional, as shiny by the reflection of light, and with different display surfaces depending on viewing angles).



(Note) Because multiple display surfaces are stated in a single drawing, no changes of a mark's states can be recognized from its prior to next states due to an effect by which different display surfaces are seen depending on different viewing angles.

(2) Example recognizable as a hologram mark

Changes of its states caused by visual effects based on holography and other means can be recognized from a trademark stated in its application, and whose detailed description of the trademark provides a statement which makes it recognizable as a hologram mark.

(Example) Hologram mark in which multiple display surfaces are indicated

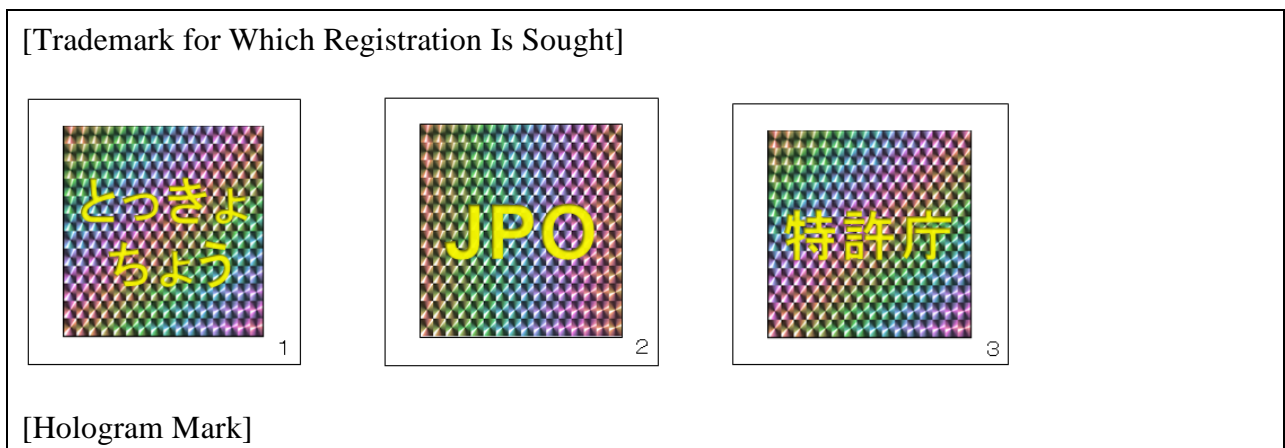

[Detailed Description of Trademark]

A trademark for which registration is sought (hereinafter referred to as the “trademark”) is a hologram mark showing different display surfaces depending on viewing angles.

Its displays seen from the left, the front and the right are shown in Drawings 1, 2 and 3, respectively.

Furthermore, the numbers shown at the lower left are provisionally provided to indicate the sequence of the drawings, and do not constitute a part of the trademark.

9. Color mark

A trademark stated as a color mark but not so recognized from a trademark stated in its application and its detailed description of the trademark shall be judged not to fall within the category of trademarks registerable in accordance with the main paragraph of Article 3(1).

(1) Example not recognizable as a color mark

(a) A color mark which evidently represents specific characters, figures, etc. from a trademark stated in its application



(b) It is not recognized that the position in goods, etc. to which colors are attached is identified from a trademark stated in its application.

[Trademark for Which Registration Is Sought]

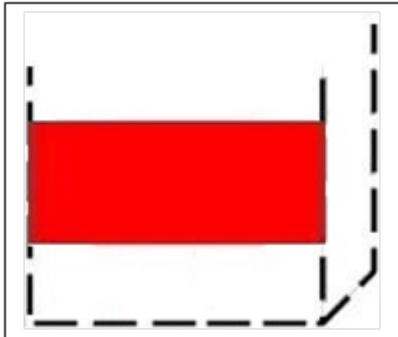

[Color Mark]

[Detailed Description of Trademark]

A trademark for which registration is sought (hereinafter referred to as the “trademark”) is a color mark. The front central part of a packaging container of goods consists of only red (RGB combination: R255, G0, B0).

It must be noted that dotted lines shown are for explanation purposes only, and do not constitute a part of the trademark.

[Designated Goods or Designated Services and Classification of Goods and Services]

[Class 5]

[Designated Goods (Designated Services)] Pharmaceutical preparations

(Note) In this case, because the dotted lines representing the packaging container to which the mark is attached do not show the entire image, the position where the mark is attached is not specified and its position in the goods cannot be identified.

Furthermore, an amendment to change a trademark for which registration is sought falls under the change of gist.

(c) The detailed description of the trademark provides a statement which makes a mark recognizable as a combination of colors and figures.

[Trademark for Which Registration Is Sought]

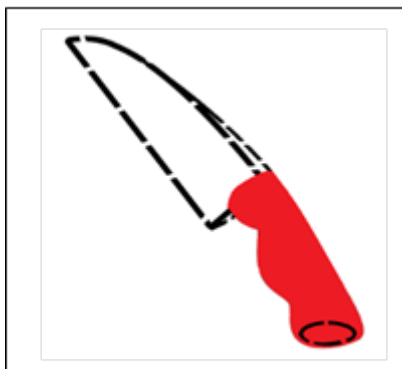

[Color Mark]

[Detailed Description of Trademark]

A trademark for which registration is sought (hereinafter referred to as the “trademark”) is a color mark whose configuration is such that it consists only of the wave shape of a kitchen knife’s handle colored in red (RGB combination: R255, G0 and B0). It must be noted that dotted lines shown are for explanation purposes only, and do not constitute a part of the trademark.

[Designated Goods or Designated Services and Classification of Goods and Services]

[Class 8]

[Designated Goods (Designated Services)] Kitchen Knife

(Note) In this case, the mark is recognized as a combination of a three-dimensional shape and a color based on the detailed description of the trademark. Therefore, the trademark will receive a notification of reason for refusal stating that it does not fall within the category of trademarks registrable in accordance with the main paragraph of Article 3(1) and Article 5(5). In response to this notification, it is required for the applicant to make an amendment in the detailed description of the trademark to clarify that the mark consists only of colors. For example, it can be explained that “the mark consists of a kitchen knife’s handle colored in red (RGB combination: R255, G0 and B0).”

(d) A shape of goods, etc. described to identify the position to which a color is attached cannot be supposed to be a shape of the designated goods, etc.

[Trademark for Which Registration Is Sought]



[Color Mark]

[Detailed Description of Trademark]

A trademark for which registration is sought (hereinafter referred to as the “trademark”) is a color mark whose configuration is such that a kitchen knife’s handle is colored in red (RGB combination: R255, G0 and B0).

It must be noted that dotted lines resembling a kitchen knife and a handle of the kitchen knife shown are for explanation purposes only, and do not constitute a part of the trademark.

[Designated Goods or Designated Services and Classification of Goods and Services]

[Class 8]

[Designated Goods (Designated Services)] Kitchen Knife, hand hair clipper

(Note) In this case, the goods “hand hair clipper” are not supposed to be a kitchen knife’s handle part, the trademark will receive a notification of reason for refusal stating that it does not fall within the category of trademarks registrable in accordance with the main paragraph of Article 3(1). In response to this notice, it is required for the applicant to make an amendment to eliminate “hand hair clipper” so that the designated goods are described as only “kitchen knife.”

(2) Example recognized as a color mark

(a) It can be recognized from a trademark stated in its application that a mark consists only of colors and whose detailed description of the trademark provides a statement which seems to make it recognizable as a color mark.

(Example 1) Single color

[Trademark for Which Registration Is Sought]



[Color Mark]

[Detailed Description of Trademark]

A trademark for which registration is sought is a color mark which consists of only red (RGB combination: R255, G0, B0).

(Example 2) Combination of colors

[Trademark for Which Registration Is Sought]



[Color Mark]

[Detailed Description of Trademark]

A trademark for which registration is sought (hereinafter referred to as the “trademark”) is one which consists of only combination of colors. The types of combination are red (RGB combination: R255, G0, B0), blue (RGB combination: R0, G0, B255), yellow (RGB combination: R255, G255, B0), and green (RGB combination: R0, G128, B0), and the percentage values of these colors from the first to the last are 50% for red, 25% for blue, 15% for yellow and 10% for green.

(b) For a trademark consisting of only colors whose positions in goods or others are specified, a trademark stated in its application is displayed whose configuration is such that the said colors and their positions in its goods or others can be specified by drawing colors for which registration is sought with only the said colors and other parts with dotted lines, and whose detailed description of the trademark provides a statement which makes it recognizable as a color mark.

(Example 1) Trademark which specifies specific positions in goods, etc.

[Trademark for Which Registration Is Sought]

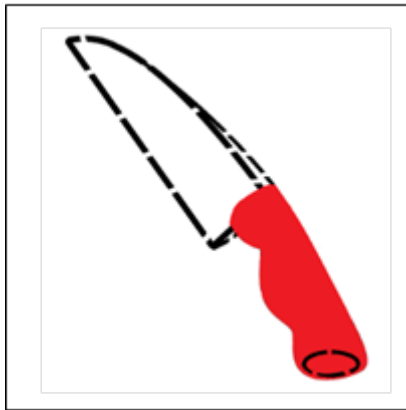

[Color Mark]

[Detailed Description of Trademark]

A trademark for which registration is sought (hereinafter referred to as the “trademark”) is a color mark whose configuration is such that a kitchen knife’s handle is colored in red (RGB combination: R255, G0 and B0).

It must be noted that dotted lines showing a shape of the goods are for explanation purposes only, and do not constitute a part of the trademark.

[Designated Goods or Designated Services and Classification of Goods and Services]

[Class 8]

[Designated Goods (Designated Services)] Kitchen Knife

(Example 2) Trademark which identifies positions in goods, etc.

[Trademark for Which Registration Is Sought]

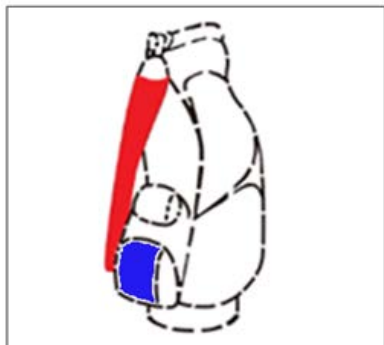

[Color Mark]

[Detailed Description of Trademark]

A trademark for which registration is sought (hereinafter referred to as the “trademark”) is a color mark whose configuration is such that a golf club bag’s belt is colored in red (RGB combination: R255, G0 and B0) and the frontal part of its pocket in blue (RGB combination: R36, G26, B240).

It must be noted that dotted lines resembling a golf club bag are only for purposes to explain how a golf club bag might look like, and do not constitute a part of the trademark.

[Designated Goods or Designated Services and Classification of Goods and Services]

[Class 28]

[Designated Goods (Designated Services)] Golf Club Bag

10. Sound Mark

A trademark stated as a sound mark but not so recognized from a trademark stated in its application, its article provided for in an Ordinance of the Ministry of Economy, Trade and Industry (hereinafter referred to as the “article”) and its detailed description of the trademark shall be judged not to fall within the category of trademarks registerable in accordance with the main paragraph of Article 3(1).

(1) Example not recognizable as a sound mark

(a) A trademark stated in its application describes an element other than those necessary for specifying sound such as music titles, names of composers, etc.

(b) A trademark stated in its application is stated by a method other than those prescribed in Article 4(5) of the Enforcement Ordinance of the Trademark Act.

(Example 1) A trademark is stated by a sound spectrogram (sonogram) notation.

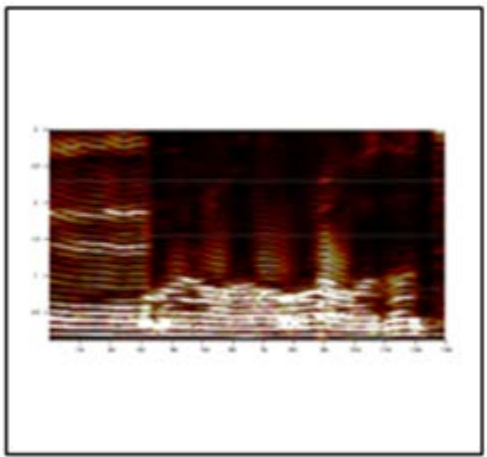

(Note) A sound spectrogram (sonogram) is a method to record and display sound in three dimensions, sound frequencies and distributions of amplitudes and time passage, through a sound analysis device.

(Example 2) A trademark is stated by a tablature notation (tab and playing method notations) or a letter notation.

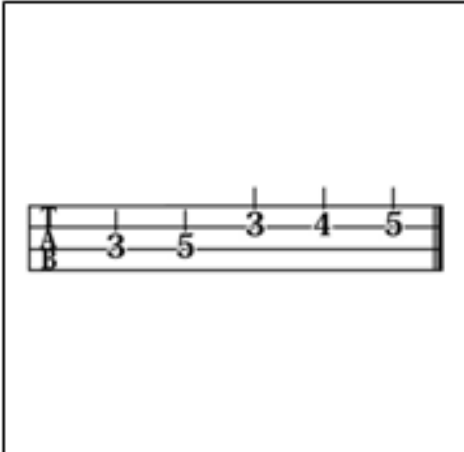

(Note) A tablature notation is a musical score which uses characters and numerals to show a playing method specific to an instrument, and currently it is frequently used as a musical score for a guitar.

(2) Examples recognized as a sound mark

A trademark stated in its application is described by a method prescribed in Article 4(5) of the Enforcement Ordinance of the Trademark Act and includes all the following items to specify sound.

(a) Where any of the following items is stated in a full score.

(i) Musical notes

- (ii) Clefs such as treble clefs
- (iii) Tempos such as metronomic indications and tempo marks
- (iv) Time signatures such as four-four times
- (v) Linguistic elements when lyrics and others are included

(Example 1)



(Example 2)

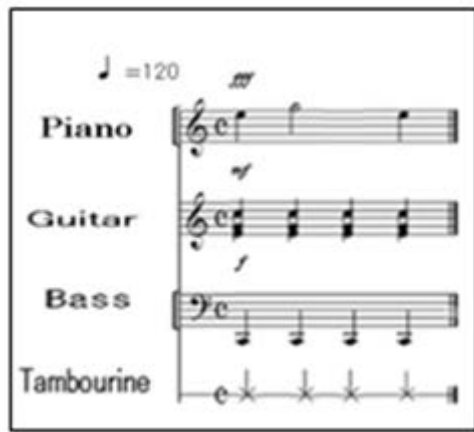

A musical score for a full band arrangement. It includes four staves: Piano, Guitar, Bass, and Tambourine. The tempo is marked as quarter note = 120. The Piano part has a dynamic marking of *mf* and consists of three quarter notes: G4, A4, and B4. The Guitar part has a dynamic marking of *mf* and consists of three chords: G4, A4, and B4. The Bass part has a dynamic marking of *f* and consists of three quarter notes: G2, A2, and B2. The Tambourine part consists of three quarter notes, each marked with an asterisk to indicate a strike.

(Note) One line staves can be used, as needed, in addition to a full score.

(Example 3)

[Trademark for which Registration is Sought]



[Sound Mark]

[Detailed Description of Trademark]

A trademark for which registration is sought (hereinafter referred to as the “trademark”) is a sound mark whose configuration is such that it is played by using a tambourine which is a percussion instrument without pitch.

The trademark describes the score by using the third line in a full score as one line staves.

(Note) A sound mark can be described as one line staves for a percussion instrument using one line in a full score only if a percussion instrument without pitch is used.

(b) Characters are used to describe the following items in a trademark.

(i) Sound types

Methods such as that to combine onomatopoeic and mimetic words are used to specify a sound mark (for example, sounds such as a cat’s “meow”, human hands’ “clapping”, wind’s “whizzing,” wind’s “roaring,” a machine’s “clicking” and a machine’s “whirring”).

(ii) Other elements required to specify sounds

How long a sound lasts (time), how many times a sound is iterated, in what sequence a sound is generated, how a sound changes and other specifications will be described.

Furthermore, how a sound changes means how a sound volume changes, how strong or weak a sound is, how a sound’s tempo changes and other aspects.

(Example)

本商標は、「パンパン」と2回手をたたく音が聞こえた後に、「ニャオ」という猫の鳴き声が聞こえる構成となっており、全体で3秒間の長さである。

11. Position Mark

A trademark stated as a position mark but not so recognized from a trademark stated in its application and its detailed description of the trademark shall be judged not to fall within the category of trademarks registerable in accordance with the main paragraph of Article 3(1).

(1) Example not recognizable as a position mark

(a) A position to which the mark is attached cannot be recognized from a trademark stated in its application.

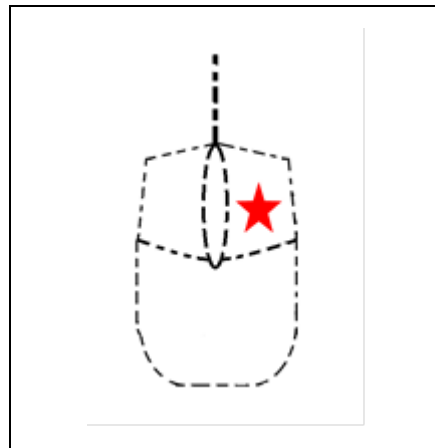
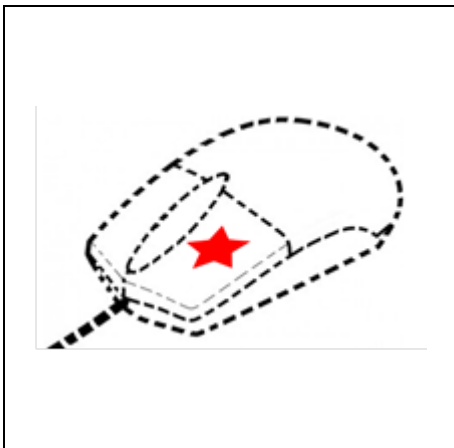

(Note) Positions of marks (figures) are different in multiple drawings shown, and it cannot be determined to which part in its goods the mark is attached.

(b) The trademark described in its application and the detailed explanation thereof contain a statement which makes it recognizable as that the mark is only composed of color.

[Trademark for Which Registration Is Sought]

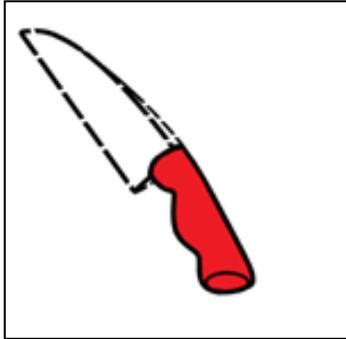

[Position Mark]

[Detailed Description of Trademark]

A trademark for which registration is sought (hereinafter, referred to as the “trademark”) is a position mark whose configuration is such that a kitchen knife’s handle is colored in red.

It must be noted that dotted lines shown are only provided to show a shape of the trademark’s goods, and does not constitute a part of the trademark.

[Designated Goods or Designated Services and Classification of Goods and Services]

[Class 8]

[Designated Goods (Designated Services)] Kitchen Knife

(Note) A position mark is, in accordance with Article 4(6) of the Enforcement Ordinance of the Trademark Act, limited to “characters, figures, symbols or three-dimensional shapes, or a combination thereof or a combination thereof with colors” as a requirement for marks, and it is not allowed that a mark consist of “only colors.” Therefore, it is required to clarify in the detailed description of the trademark what is a mark connected with colors like. In this case, the description of “a kitchen knife’s handle is colored in red” can be interpreted that a mark colored in “red” is attached to the “kitchen knife’s handle, so that the mark can be recognized to be composed of only colors.

Therefore, the trademark will receive a notification of reason for refusal stating that the trademark does not fall within the category of trademarks registrable in accordance with the main paragraph of Article 3(1) and Article 5(5) simultaneously. In this case, it is required for the applicant to make an amendment in the detailed description of the trademark to clarify that the mark consists of a combination of a three-dimensional shape and colors. For example, the detailed explanation of the trademark can say that “the mark consists of a three-dimensional shape whose kitchen knife’s

handle is colored in red.”

(c) A shape of a good, etc. stated to specify its position cannot be supposed as a shape of the designated goods, etc.

[Trademark for Which Registration Is Sought]

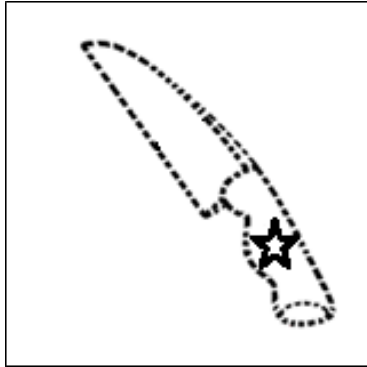

[Position Mark]

[Detailed Description of Trademark]

A trademark for which registration is sought (hereinafter, referred to as the “trademark”) is a position mark whose configuration is such that a position to which a mark is attached is specified and consists of a star-shaped figure attached to the central part of a side of the kitchen knife’s handle.

It must be noted that dotted lines are only provided to show a shape of the trademark’s goods, and does not constitute a part of the trademark.

[Designated Goods or Designated Services and Classification of Goods and Services]

[Class 8]

[Designated Goods (Designated Services)] Scissors, kitchen knife, swords, ink bottles

(Note) In this case, a position equivalent to the kitchen knife’s handle cannot be specified by the goods “scissors and ink bottles,” Therefore, the trademark will receive a notification of reason for refusal stating that the trademark does not fall within the category of trademarks registrable in accordance with the main paragraph of Article 3(1). In response to this notification, it is required for the applicant to make an amendment to limit the designated goods to “kitchen knife and swords.”

(2) Example recognized as a position mark

It can be recognized that a trademark described in its application is displayed in a way that a mark and a position in its good to which it is attached can be specified by 30 drawing the mark in real lines and other parts in dotted lines, and whose detailed description of the trademark contains a statement which makes it recognizable as a position mark.

(Example 1)

[Trademark for Which Registration Is Sought]

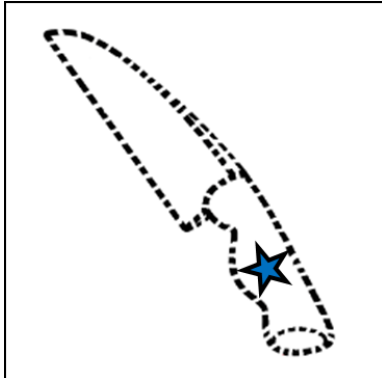

[Position Mark]

[Detailed Description of Trademark]

A trademark for which registration is sought (hereinafter, referred to as the “trademark”) is a position mark whose configuration is such that a position to which a mark is attached is specified and consists of a star-shaped figure attached to the central part of a side of the kitchen knife’s handle.

It must be noted that the dotted lines are only provided to show a shape of the trademark’s goods, and does not constitute a part of the trademark.

[Designated Goods or Designated Services and Classification of Goods and Services]

[Class 8]

[Designated Goods (Designated Services)] Kitchen Knife

(Example 2)

[Trademark for Which Registration Is Sought]



[Position Mark]

[Detailed Description of Trademark]

A trademark for which registration is sought (hereinafter referred to as the “trademark”) is a color mark whose configuration is such that a position to which a mark is attached is specified and it is attached to the lower part of a side surface of the golf club bag.

It must be noted that the dotted lines are only provided to show a shape of the trademark’s goods, and do not constitute a part of the trademark.

[Designated Goods or Designated Services and Classification of Goods and Services]

[Class 28]

[Designated Goods (Designated Services)] Golf Club Bag